

# Interdisciplinary and Cross Year Course Mentoring and Integration

Chris Short, David Legge & Nicholas Pickett (ACES)



## 1. Background

Engineering has always presented multidisciplinary challenges in the workplace and problems for the education of undergraduates (Armstrong et al 1982). Challenges have continued to become even more complex with the development of rapidly increasing technological advancement and new subject areas. The teaching of engineering undergraduates at a multidisciplinary level is still a requirement which is made problematic by the same difficulties of separate academic disciplines. Interdisciplinary project work can be used to provide a real world scenario for integrating single discipline subject knowledge

## 2. Rationale

This project, funded by the CPLA Small Project Scheme at Sheffield Hallam University is aimed at:

- Creating opportunities for enhancing engineering students' learning experiences through multidisciplinary project work
- Developing of links (initially informal) between design / mechanical engineering final year projects and taught classes in other engineering disciplines.
- Improving students ability to work autonomously on project work and in particular to manage their time effectively

## 3. Approach/ Method

Issues experienced during this CPLA project, include issues of;

- time management
- motivation when doing extended projects
- project management and supervision etc

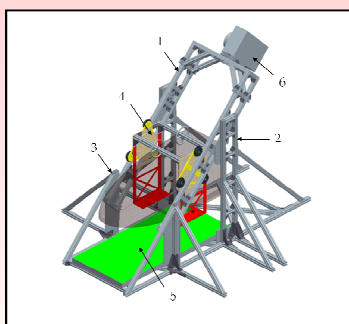

Qualitative data in relation to the above issues (in relation to developing these skills as a framework for developing autonomy) was analysed against the background of specific case studies based on six final year aerospace flavoured interdisciplinary projects, supported by both a supervisor and a mentor.

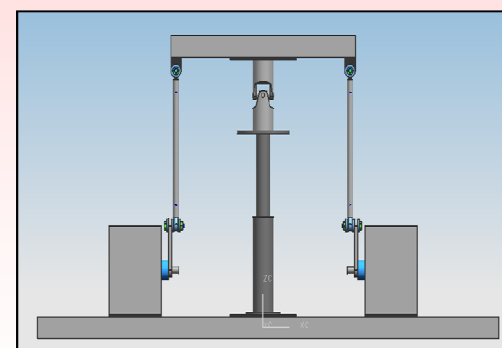
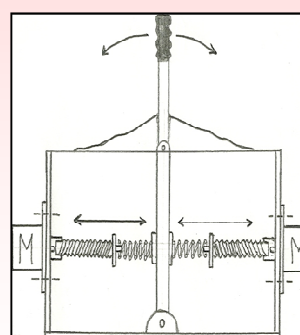
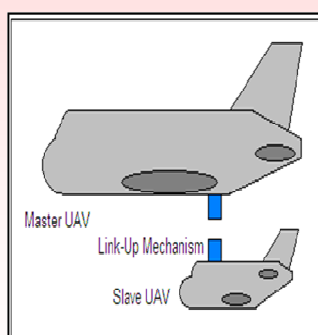
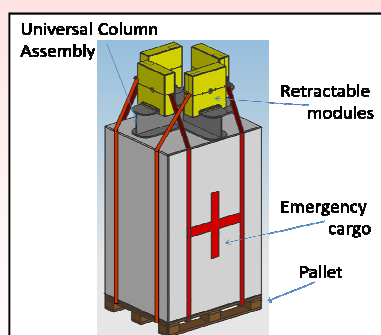

Developments for the future, including strengthening working across departments and subject boundaries with a view to formalising such links were also investigated..

## 4. Assessment

- Weekly supervisor individual and peer group meetings
- External expert mentoring via e-mail and video conferencing
  - Student project A4 flyers for use at exhibitions and fairs– leading to offers of help and employment
  - range of separate final year project assessment criteria re-project planning, independent working and time management

## 5. Evaluation

- One to one interviews  
Focus Group Interview Sessions (6 students)  
Autonomous student weekly project management/ progress reports
- Weekly supervisor individual and peer group meetings  
BB organisation site for sharing information

## 6. Comments- Interdisciplinary projects:

### Challenges

- projects were complicated and big problems
- needed expert knowledge as could be provided by a team
- needs to be a group integrated activity because of interdisciplinary areas

### Opportunities

- Integrated previous academic and placement knowledge and experience
- Provided wide learning experience of unfamiliar topics
- Range of engagement by students– Good engagement with process and autonomous motivation lead to better quality work and overall grades.

## References

Armstrong, P J; Farouki, O T; McCloy D; Undergraduate Interdisciplinary Projects, European Journal of Engineering education, 7 (1982) pg 159-170, Elsevier Scientific Publishing Company, Amsterdam

## 8. Contact Details

Dr. C. Short– Sheffield Hallam University; Tel 0114 2253457; e-mail C.short@shu.ac.uk  
Mr. N Pickett- Sheffield Hallam University; Tel 0114 2253424; e-mail nj.pickett@shu.ac.uk  
Mr. D. Legge-Sheffield Hallam University; Tel 0114 2253018, e-mail david\_ian\_legge@yahoo.co.uk